

# Powerwall 3

## Power Everything

—  
Powerwall 3 is a fully integrated solar and battery system, designed to accelerate the transition to sustainable energy. Customers can receive whole home backup, cost savings, and energy independence by producing and consuming their own energy while participating in grid services. Once installed, customers can manage their system using the Tesla App to customize system behavior to meet their energy goals.

Powerwall 3 achieves this by supporting up to 20 kW DC of solar and providing 11.5 kW AC of continuous power per unit. It has the ability to start heavy loads rated up to 185 LRA, meaning a single unit can support the power needs of most homes. Powerwall 3 is designed for fast and efficient installations, modular system expansion, and simple connection to any electrical service.



# Powerwall 3 Technical Specifications

## System Technical Specifications

Model Number	1707000-xx-y
Nominal Grid Voltage (Input & Output)	120/240 VAC
Grid Type	Split phase
Frequency	60 Hz
Overcurrent Protection Device	60 A See <a href="#">Powerwall 3 Installation Manual</a> for fuse requirements if using 60 A fuse for overcurrent protection
Solar to Battery to Home/Grid Efficiency	89% <sup>1,2</sup>
Solar to Home/Grid Efficiency	97.5% <sup>3</sup>
Supported Islanding Devices	Gateway 3, Backup Switch, Backup Gateway 2
Connectivity	Wi-Fi (2.4 and 5 GHz), Ethernet, Cellular (LTE/4G <sup>4</sup> )
Hardware Interface	Dry contact relay, Rapid Shutdown (RSD) certified switch and 2-pin connector, RS-485 for meters
AC Metering	Revenue Grade (+/- 0.5%, ANSI C12.20)
Protections	Integrated arc fault circuit interrupter (AFCI), Isolation Monitor Interrupter (IMI), PV Rapid Shutdown (RSD) using Tesla Mid-Circuit Interrupters
Customer Interface	Tesla Mobile App
Warranty	10 years

## Battery Technical Specifications

Nominal Battery Energy	13.5 kWh AC <sup>2</sup>
Maximum Continuous Discharge Power	11.5 kW AC
Output Power Factor Rating	0 - 1 (Grid Code configurable)
Maximum Continuous Charge Current / Power	20.8 A AC / 5 kW
Maximum Output Fault Current	10 kA
Load Start Capability	185 LRA
Power Scalability	Up to 4 Powerwall 3 units supported

## Solar Technical Specifications

Maximum Solar STC Input	20 kW
Withstand Voltage	600 V DC
PV DC Input Voltage Range	60 — 550 V DC
PV DC MPPT Voltage Range	60 — 480 V DC
MPPTs	6
Maximum Current per MPPT ( $I_{mp}$ )	13 A <sup>5</sup>
Maximum Short Circuit Current per MPPT ( $I_{sc}$ )	15 A <sup>5</sup>

<sup>1</sup> Typical solar shifting use case.

<sup>2</sup> Values provided for 25°C (77°F), at beginning of life. 3.3 kW charge/discharge power.

<sup>3</sup> Tested using CEC weighted efficiency methodology.

<sup>4</sup> The customer is expected to provide internet connectivity for Powerwall 3; cellular should not be used as the primary mode of connectivity. Cellular connectivity subject to network operator service coverage and signal strength.

<sup>5</sup> Where the DC input current exceeds the MPPT rating, a jumper can be used to combine two MPPTs into a single input to intake DC current up to 26 A  $I_{MP}$  / 30 A  $I_{SC}$ .

# Powerwall 3 Technical Specifications

## Environmental Specifications

Operating Temperature	-20°C to 50°C (-4°F to 122°F) <sup>6</sup>
Operating Humidity (RH)	Up to 100%, condensing
Storage Temperature	-20°C to 30°C (-4°F to 86°F), up to 95% RH, non-condensing, State of Energy (SOE): 25% initial
Maximum Elevation	3000 m (9843 ft)
Environment	Indoor and outdoor rated
Enclosure Rating	NEMA 3R
Ingress Rating	IP67 (Battery & Power Electronics) IP55 (Wiring Compartment)
Pollution Rating	PD3
Operating Noise @ 1 m	< 50 db(A) typical < 62 db(A) maximum

<sup>6</sup>Performance may be de-rated at operating temperatures above 40°C (104°F).

## Compliance Information

Certifications	UL 1741, UL 9540, UL 9540A, UL 3741, UL 1741 PCS, UL 1741 SA, UL 1741 SB, UL 1973, UL 1699B, UL 1998, CSA C22.2 No. 0.8, CSA C22.2 No. 107.1, CSA C22.2 No. 330, CSA 22.3 No. 9, IEEE 1547, IEEE 1547A, IEEE 1547.1, CA Rule No.21
Grid Connection	United States and Canada
Emissions	FCC Part 15 Class B, ICES 003
Environmental	RoHS Directive 2011/65/EU
Seismic	AC156, IEEE 693-2005 (high)
Fire Testing	Meets the unit level performance criteria of UL 9540A

## Mechanical Specifications

Dimensions	1099 x 609 x 193 mm (43.25 x 24 x 7.6 in)
Weight	130 kg (287 lb)
Mounting Options	Floor or wall mount

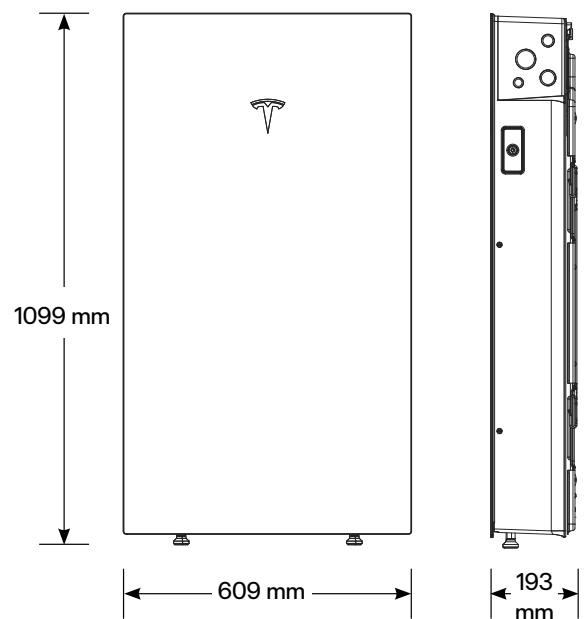

# Solar Shutdown Device Technical Specifications

The Solar Shutdown Device is a Mid-Circuit Interrupter (MCI) and is part of the PV system rapid shutdown (RSD) function in accordance with Article 690 of the applicable NEC. When paired with Powerwall 3, solar array shutdown is initiated by any loss of AC power.

## Electrical Specifications

Model	MCI-1	MCI-2
Nominal Input DC Current Rating ( $I_{MP}$ )	13 A	13 A
Maximum Input Short Circuit Current ( $I_{SC}$ )	19 A	17 A
Maximum System Voltage (PVHCS)	600 V DC	1000 V DC <sup>7</sup>

<sup>7</sup> Maximum System Voltage is limited by Powerwall to 600 V DC.

## RSD Module Performance

Maximum Number of Devices per String	5
Control	Power Line Excitation
Passive State	Normally Open
Maximum Power Consumption	7 W
Warranty	25 years

## Environmental Specifications

Operating Temperature	-40°C to 50°C (-40°F to 122°F)	-45°C to 70°C (-49°F to 158°F)
Storage Temperature	-30°C to 70°C (-22°F to 158°F)	-30°C to 70°C (-22°F to 158°F)
Enclosure Rating	NEMA 4X / IP65	

## Mechanical Specifications

Electrical Connections	MC4 Connector	
Housing	Plastic	
Dimensions	125 x 150 x 22 mm (5 x 6 x 1 in)	173 x 45 x 22 mm (6.8 x 1.8 x 1 in)
Weight	350 g (0.77 lb)	120 g (0.26 lb)
Mounting Options	ZEP Home Run Clip M4 Screw (#10) M8 Bolt (5/16") Nail / Wood screw	Wire Clip

## Compliance Information

Certifications	UL 1741 PVRSE, UL 3741, PVRSA (Photovoltaic Rapid Shutdown Array)
RSD Initiation Method	External System Shutdown Switch or Powerwall 3 Enable Switch

## UL 3741 PV Hazard Control (and PVRSA) Compatibility

See Powerwall 3 Installation Manual

# Gateway 3

Tesla Gateway 3 controls connection to the grid in a Powerwall system, automatically detecting outages and providing seamless transition to backup power. It provides energy monitoring that is used by Powerwall for solar self-consumption, time-based control, and backup operation.

## Performance Specifications

<b>Model Number</b>	1841000-01-y	<b>AC Meter</b>	+/- 0.5%
<b>Nominal Grid Voltage</b>	120/240 V AC	<b>Communication</b>	CAN
<b>Grid Configuration</b>	Split phase	<b>User Interface</b>	Tesla App
<b>Grid Frequency</b>	60 Hz	<b>Backup Transition</b>	Automatic disconnect for seamless backup
<b>Continuous Current Rating</b>	200 A	<b>Overcurrent Protection Device</b>	100–200 A Service entrance rated Eaton CSR, BWH, or BW, or Square D QOM breakers
<b>Maximum Supply Short Circuit Current</b>	22 kA with Square D or Eaton main breaker 25 kA with Eaton main breaker <sup>8</sup>	<b>Internal Panelboard</b>	200 A 8-space/16 circuit breakers Eaton BR, Siemens QP, or Square D HOM breakers rated to 10–125A
<b>IEC Protective Class</b>	Class I	<b>Warranty</b>	10 years
<b>Overvoltage Category</b>	Category IV		

<sup>8</sup>Only Eaton CSR or BWH main breakers are 25 kA rated.

## Environmental Specifications

<b>Operating Temperature</b>	-20°C to 50°C (-4°F to 122°F)
<b>Operating Humidity (RH)</b>	Up to 100%, condensing
<b>Maximum Elevation</b>	3000 m (9843 ft)
<b>Environment</b>	Indoor and outdoor rated
<b>Enclosure Type</b>	NEMA 3R

## Compliance Information

<b>Certifications</b>	UL 67, UL 869A, UL 916, UL 1741 PCS, CSA 22.2 107.1, CSA 22.2 29
<b>Emissions</b>	FCC Part 15, Class B, ICES 003

## Mechanical Specifications

<b>Dimensions</b>	660 x 411 x 149 mm (26 x 16 x 6 in)
<b>Weight</b>	16.3 kg (36 lb)
<b>Mounting options</b>	Wall mount

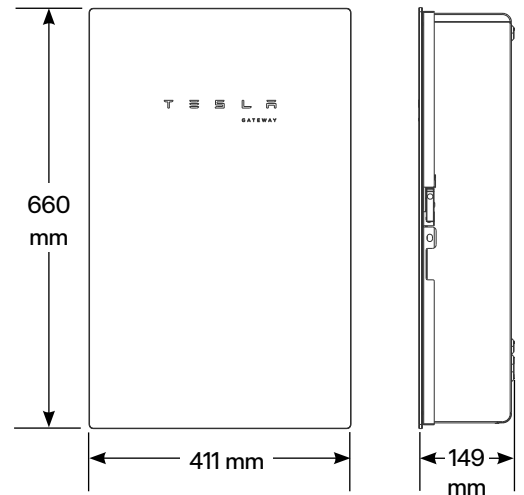

# Backup Switch

The Tesla Backup Switch controls connection to the grid in a Powerwall system, and can be easily installed behind the utility meter or in a standalone meter panel downstream of the utility meter.

The Backup Switch automatically detects grid outages, providing a seamless transition to backup power. It communicates directly with Powerwall, allowing home energy usage monitoring from any mobile device with the Tesla app.

## Performance Specifications

Model Number	1624171-xx-y
Continuous Load Rating	200 A, 120/240 V split phase
Maximum Supply Short Circuit Current	22 kA with breaker <sup>9</sup>
Communication	CAN
AC Meter	+/- 0.5%
Expected Service Life	21 years
Warranty	10 years

<sup>9</sup> Breaker maximum supply short circuit current rating must be equal to or greater than the available fault current.

## Environmental Specifications

Operating Temperature	-40°C to 50°C (-40°F to 122°F)
Storage Temperature	-40°C to 85°C (-40°F to 185°F)
Enclosure Rating	NEMA 3R
Pollution Rating	PD3

## Compliance Information

Safety Standards	USA: UL 414, UL 414 SB, UL 2735, UL 916, CA Prop 65
Emissions	FCC Part 15, Class B, ICES 003

## Mechanical Specifications

Dimensions	176 x 205 x 74 mm (6.9 x 8.1 x 2.9 in)
Weight	2.8 lb
Meter and Socket Compatibility	ANSI Type 2S, ringless or ring type
External Service Interface	Contactor manual override <sup>10</sup> Reset button
Conduit Compatibility	1/2-inch NPT

<sup>10</sup> Manually overrides the contactor position during a service event.

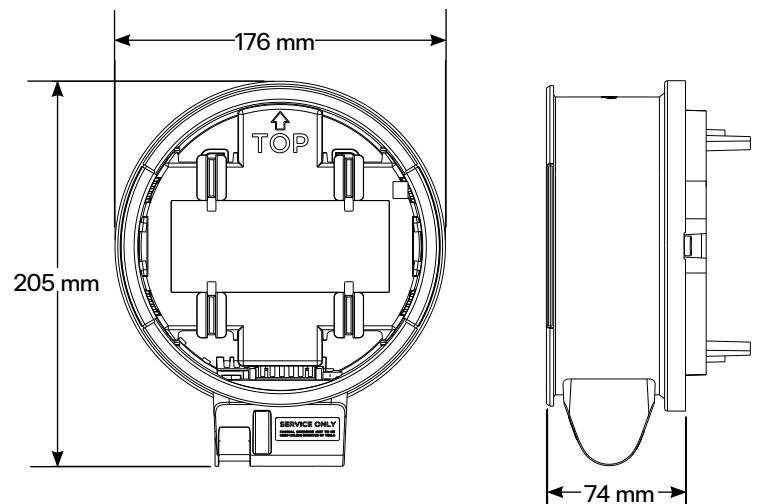

# Backup Gateway 2

Backup Gateway 2 controls connection to the grid when paired with Powerwall 3, automatically detecting outages and providing seamless transition to backup power. Backup Gateway 2 also provides energy metering for solar self-consumption, time-based control, and backup operation.

In this system configuration, Powerwall 3 acts as the Site Controller, with the Backup Gateway 2 Site Controller disabled.

## Performance Specifications

Model Number	1232100-xx-y
AC Voltage (Nominal)	120/240 V
Feed-in Type	Split phase
Grid Frequency	60 Hz
Current Rating	200 A
Maximum Supply Short Circuit Current	10 kA <sup>11</sup>
Overcurrent Protection Device	100 - 200 A, Service entrance rated
Overvoltage Category	Category IV
Internal Primary AC Meter	+/- 0.2%
Internal Auxiliary AC Meter	+/- 2%
Primary Connectivity	Ethernet, Wi-Fi
Secondary Connectivity	Cellular (3G, LTE/4G) <sup>12</sup>

User Interface	Tesla App
Operating Modes	Support for solar self-consumption, time-based control, and backup
Backup Transition	Automatic disconnect for seamless backup
Modularity	Supports up to 10 AC-coupled Powerwalls
Optional Internal Panelboard	200 A 6-space / 12 circuit breakers Siemens QP or Square D HOM breakers rated 10 - 80A or Eaton BR breakers rated 10 - 125A
Warranty	10 years

<sup>11</sup> When protected by Class J fuses, Backup Gateway 2 is suitable for use in circuits capable of delivering not more than 22kA symmetrical amperes.

<sup>12</sup> Cellular connectivity subject to network operator service coverage and signal strength.

## Environmental Specifications

Operating Temperature	-20°C to 50°C (-4°F to 122°F)
Operating Humidity (RH)	Up to 100%, condensing
Maximum Elevation	3000 m (9843 ft)
Environment	Indoor and outdoor rated
Enclosure Type	NEMA 3R

## Compliance Information

Certifications	UL 67, UL 869A, UL 916, UL 1741 PCS, CSA 22.2 0.19, CSA 22.2 205
Emissions	FCC Part 15, Class B, ICES 003

## Mechanical Specifications

Dimensions	660 x 411 x 149 mm (26 x 16 x 6 in)
Weight	20.4 kg (45 lb)
Mounting options	Wall mount, Semi-flush mount

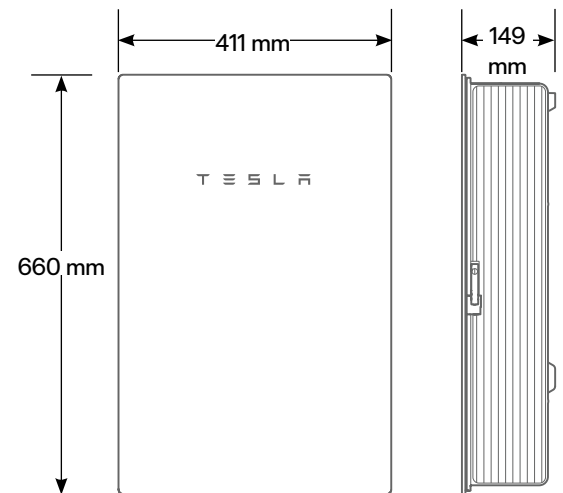

# Powerwall 3 Example System Configurations

## Powerwall 3 with Gateway 3

Whole Home Backup

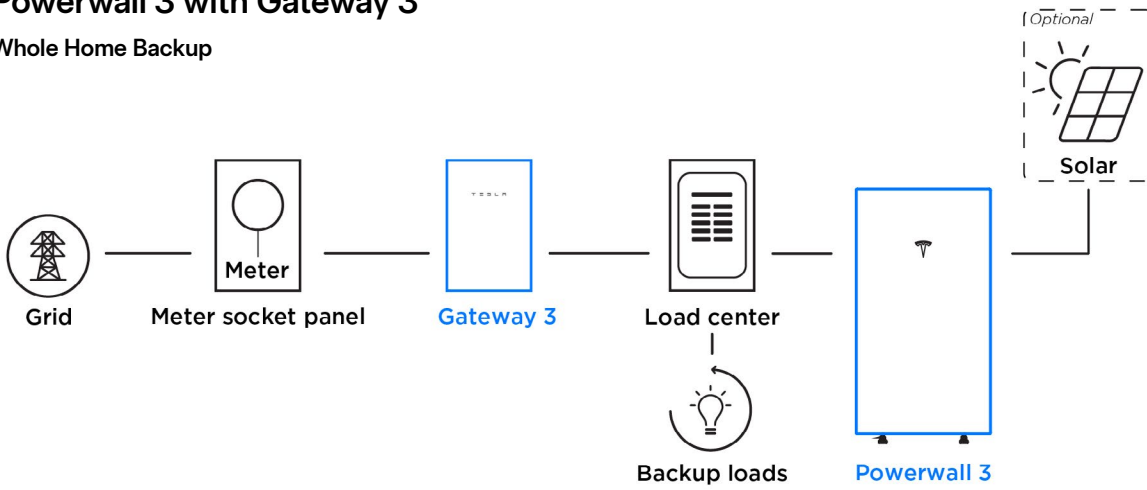

## Powerwall 3 with Backup Switch

Whole Home Backup

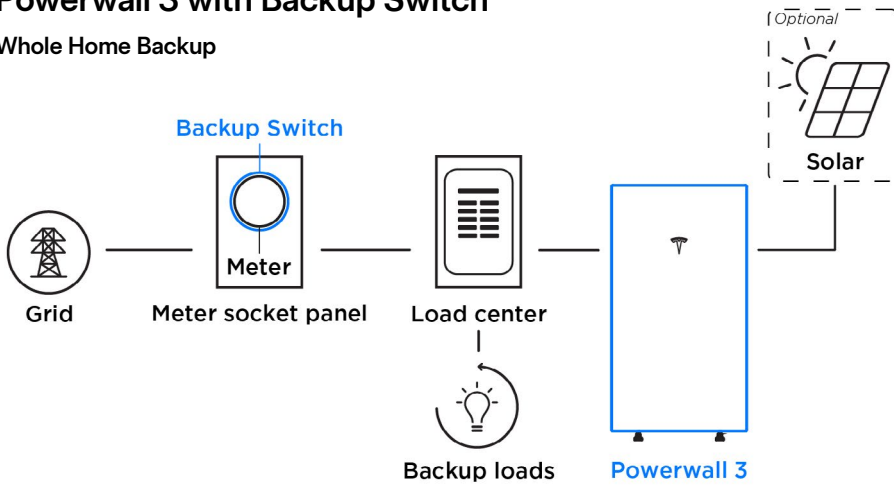

## Powerwall 3 with Backup Gateway 2

Partial Home Backup

